

SUPERSEDES: July 9, 2015

Effective: August 5, 2021

Plant ID No. 001-4195

APPLICATION:

- Maximum operating pressure is 125 psi (862 kPa).
- Maximum water temperature not to exceed nameplate rating.
- Cast iron circulators are to be used for closed loop systems only.
- Taco Cartridge circulator pumps are for indoor use only – employer uniquement a l'interieur.
- For use with water or maximum of 50% glycol/water mix systems only.

WARNING: Do not use in swimming pool or spa areas; pump has not been investigated for this application.

WARNING: In the event the electrical box has been pulled off of the housing, DO NOT attempt to reattach it. Use of any other screw may short out the stator windings, creating a risk of electrical shock.

CAUTION: When installing electrical connections, do not apply mechanical loads to the capacitor box; otherwise, retaining screws may be pulled out of the housing, making circulator unusable.

CAUTION: 1. The addition of petroleum based fluids or certain chemical additives to systems utilizing TACO equipment voids the warranty.

2. Use supply wires suitable for 90°C – ATTENTION: Employer des fils d'alimentation adequats pour 90°C.

WARNING: To avoid electrical shock, disconnect the power supply to the circulator and the main electrical unit.

FIGURE 1

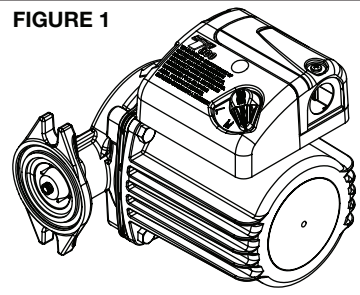
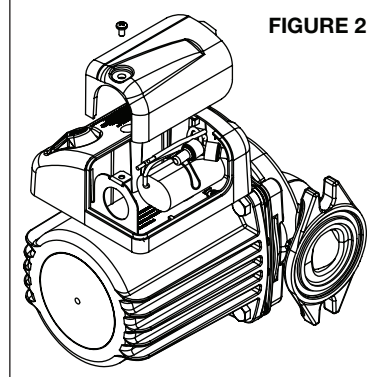

FIGURE 2



INSTALLATION:

CAUTION: Installations at higher elevations over 5000 feet must have higher fill pressure of 20 psi minimum to prevent pump cavitation and flashing. Premature failure may result. Adjust expansion tank pressure to equal fill pressure. A larger size expansion tank may be required.

1. Location – Install the “00” circulator on the system supply side of the boiler “pumping away” from the expansion tank as shown in Figures 4, 5, and 6. This is the best pump location for optimum system performance and maintaining positive system pressure.

CAUTION: Do not use flat rubber gaskets. Only use o-ring gaskets provided or leaks may result. Warranty will be void.

2. Mounting position – Mount circulator with the motor in the horizontal position. It may be mounted vertically with the motor up, provided that the system cold fill pressure is at least 20 psi (138 kPa) to ensure proper air purging and prevent flashing. Make sure that the junction box is NOT located underneath the circulator. See Figure 3.
3. Rotating body – Body has an arrow on the front that indicates direction of flow. To rotate body, remove the four body bolts, rotate body and replace bolts.
4. Electrical connections – Observe all applicable codes when connecting to power supply. The motor is thermally protected, and does not require additional overload protection. Remove smaller conduit box cover. Attach the white wire to the white (common) power supply wire and the yellow wire to the black (hot) power supply wire. See Figure 2.
5. Fill system with tap water or maximum 50% glycol/water mix – The system must be filled before operating the circulator. The bearings are water lubricated and should not be allowed to operate dry. Filling the system will result in immediate lubrication of the bearings. It is always good practice to flush a new system of foreign matter before starting the circulator.
6. Circulator operation – Operate the circulator for 5 minutes at full speed immediately after flushing the system to purge remaining air from the cartridge. This is especially important when installing the circulator during the off-season.
7. Turn speed dial on circulator to the desired speed and performance range. See Page 3 for performance curves.

FIGURE 3

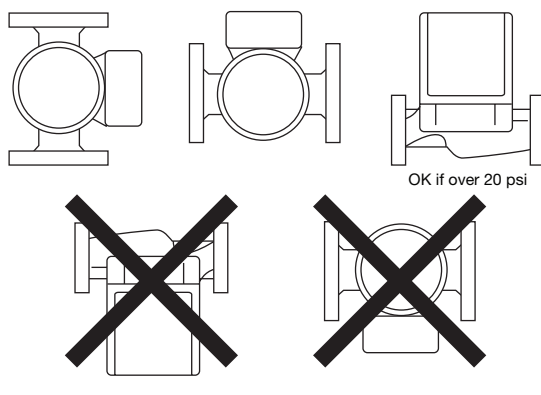
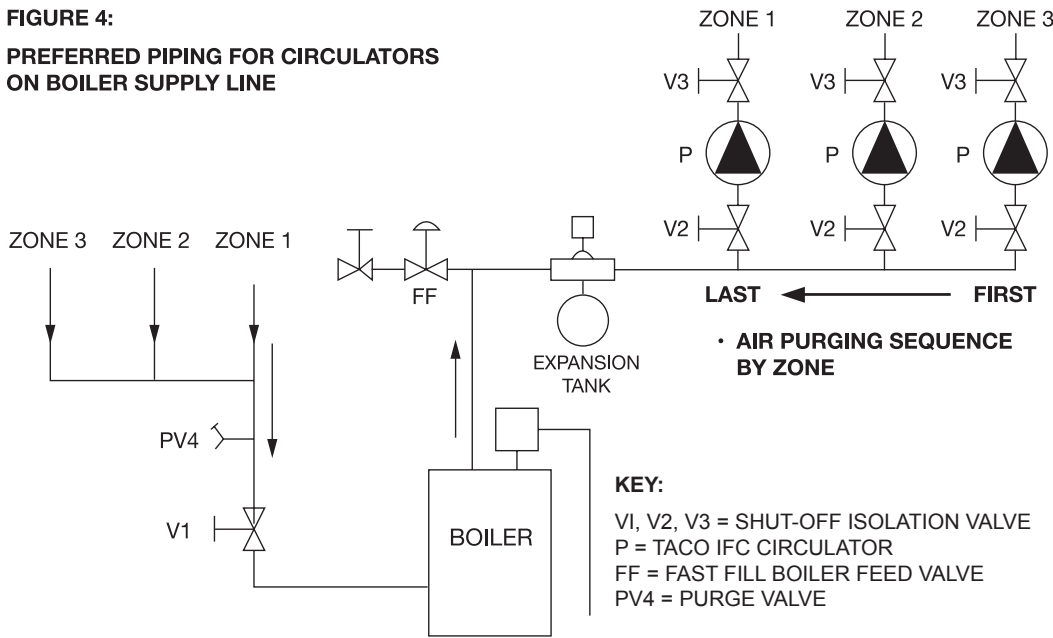

FIGURE 4:
PREFERRED PIPING FOR CIRCULATORS
ON BOILER SUPPLY LINE



RECOMMENDED PURGING STEPS:

1. CLOSE V1, PV4, V2
2. OPEN V3
3. OPEN FF VALVE
4. OPEN V2, PV4, TO PURGE LAST ZONE FIRST (ZONE 3)
5. CLOSE FF VALVE
6. CLOSE V2, PV4
7. REPEAT STEPS 1 TO 6 FOR EACH ADDITIONAL ZONE, PURGE ZONE 1 LAST
8. OPEN V1 WHEN ALL ZONES ARE PURGED
9. ADJUST SYSTEM TO DESIRED OPERATING FILL PRESSURE IF REQUIRED
10. MOVE ALL ZV TO CLOSED/AUTOMATIC POSITION

FIGURE 5:
PREFERRED PIPING FOR ZONE VALVES
ON BOILER SUPPLY LINE

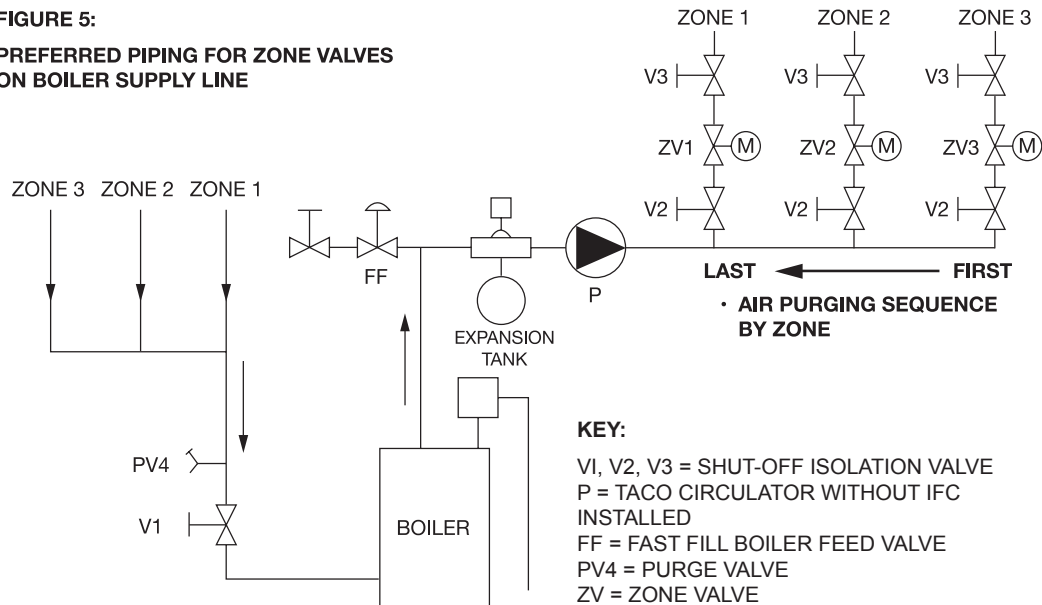

RECOMMENDED PURGING STEPS:

1. CLOSE V1, PV4, V2
2. OPEN V3 AND ZV3
3. OPEN FF VALVE
4. OPEN V2, PV4, TO PURGE LAST ZONE FIRST (ZONE 3)
5. CLOSE FF VALVE
6. CLOSE V2, PV4
7. REPEAT STEPS 1 TO 6 FOR EACH ADDITIONAL ZONE, PURGE ZONE 1 LAST
8. OPEN V1 WHEN ALL ZONES ARE PURGED
9. ADJUST SYSTEM TO DESIRED OPERATING FILL PRESSURE IF REQUIRED
10. MOVE ALL ZV TO CLOSED/AUTOMATIC POSITION

FIGURE 6:
ALTERNATE PIPING FOR ZONE VALVES
ON BOILER RETURN LINE

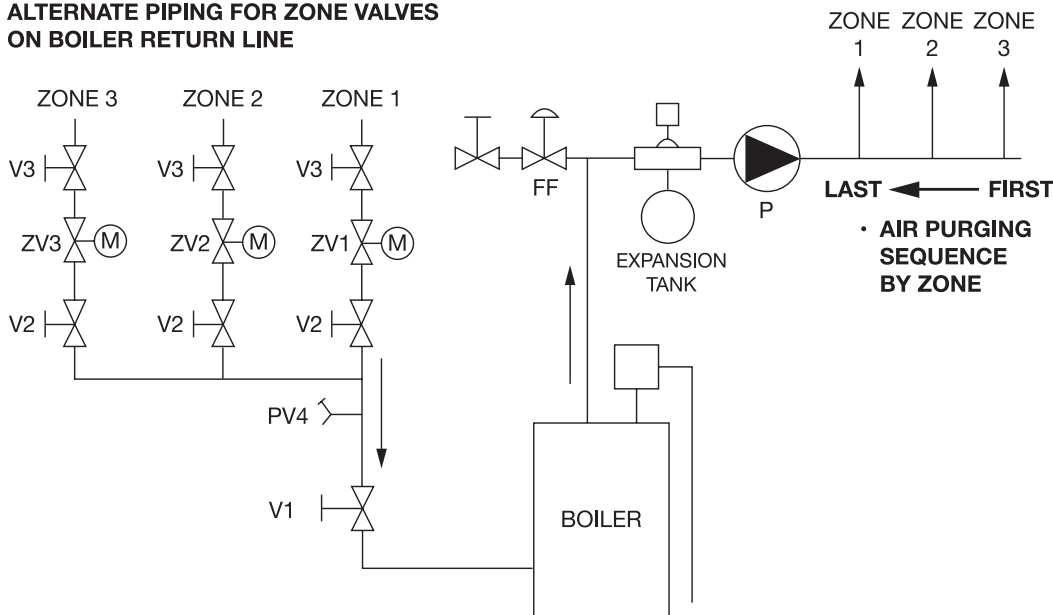

60 Hz PERFORMANCE FIELD:

0012 3-Speed

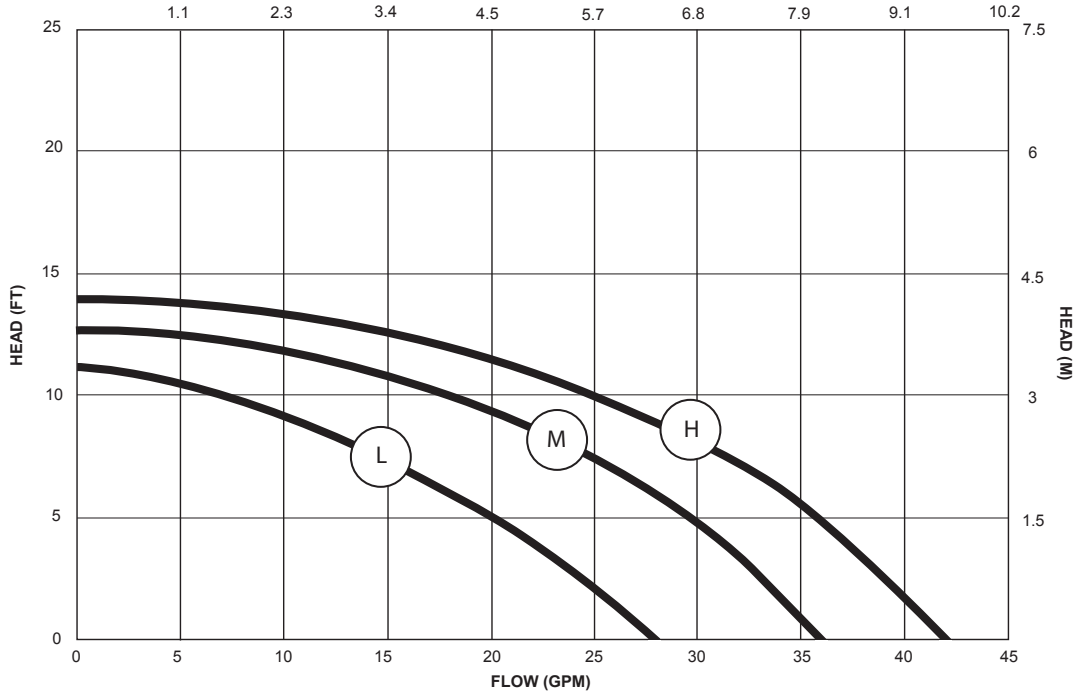

0013 3-Speed

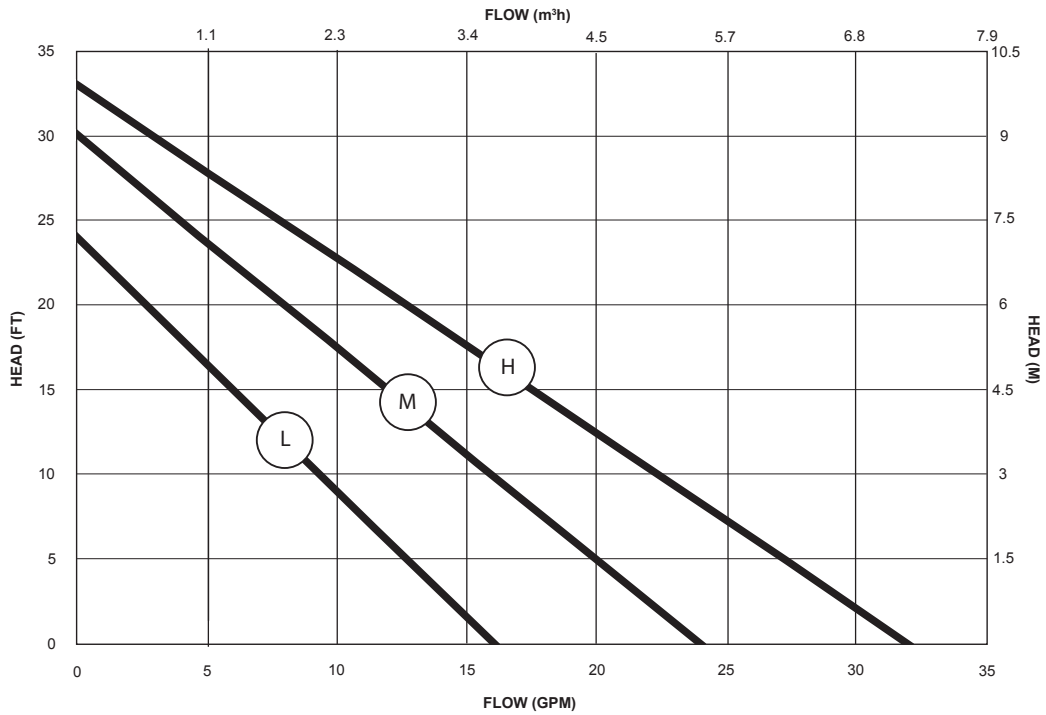

PUMP REPLACEMENT CROSS REFERENCE:

3-SPEED MODELS			
TACO	Armstrong	Grundos	B & G
0012-MSF1-IFC	Astro290	UPS43-44FC	NRF-45
0013-MSF1-IFC	Astro280	UPS26-99FC	NRF-36

PROPER REMOVAL/REPLACEMENT OF THE INTEGRAL FLOW CHECK (IFC):

Your "00" circulator with an Integral Flow Check (IFC) is designed for easy removal, service and replacement. Please follow these instructions to ensure proper service and operation of the circulator.

REMOVAL:

1. Disconnect power to circulator and related equipment.
2. Shut off water supply. Isolate circulator using service valves or drain system if valves are not available.
3. Allow system to cool to prevent scalding. Loosen flange bolts slowly to relieve system pressure and remove circulator from the system. Access the IFC located in the discharge flange (Figure 8).
4. Using needle nose pliers, carefully grip the IFC body and remove slowly.

REPLACEMENT:

1. Make sure the IFC pocket is clean and free of any debris.
2. Position IFC into the machined pocket inside the casing as shown in Figure 8. Firmly press the IFC into the pocket until it snaps into place.
3. Reinstall circulator with new flange gaskets, if required.
4. Open water supply and refill system. Check for any leaks.
5. Reconnect power to circulator and check for proper operation of system.

REPLACING MOTOR:

1. Disconnect the electrical supply.
2. Reduce system pressure to 0 psi and allow system to return to room temperature. Isolate the circulator by closing the service valves or draining the system.
3. Remove the body bolts and swing motor assembly away from the body.
4. Transfer impeller cartridge from old motor to new motor making sure the cover plate is between the cartridge flange and motor housing.
5. Install new motor, and reassemble circulator using the new gasket and bolts supplied.
6. Follow the "installation" procedure to start up the circulator

REPLACING CARTRIDGE ASSEMBLY:

1. Disconnect the electrical supply.
2. Reduce system pressure to 0 psi and allow system to return to room temperature. Isolate the circulator by closing the service valves or draining the system.
3. Remove the body bolts and swing motor assembly away from the body.
4. Pull cartridge out of the motor housing.
5. Install replacement cartridge, making sure that the cover plate is between the cartridge flange and motor.
6. Make sure the replacement cartridge corresponds to the full circulator product number. A complete parts list is available from your local plumbing supply wholesaler.
7. Reassemble the circulator using the new gasket and bolts supplied.
8. Follow the "Installation" procedure to start up the circulator.

REPLACING CAPACITOR:

1. Replacement capacitor must have same rating as originally furnished.

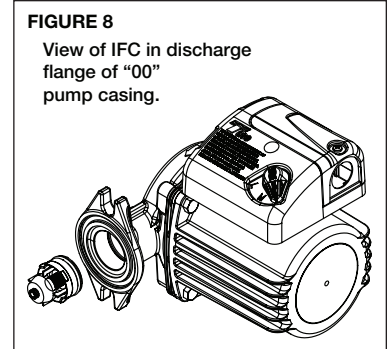

Replacement Parts				
	0012-MSF2-IFC	0012-MSSF2-IFC	0013-MSF2-IFC	0013-MSSF2-IFC
Casing O-Ring	0012-006RP		009-005RP	
Check Valve	0012-021RP			
Flange Gasket	007-007RP			
Capacitor	0013-035RP			
Plate	007-058RP			
Cartridge	0012-011RP	0012-012RP	0013-007RP	0013-008RP

LIMITED WARRANTY STATEMENT

Taco, Inc. will repair or replace without charge (at the company's option) any Taco 00 Series circulator or circulator part which is proven defective under normal use within three (3) years from the date of manufacture.

In order to obtain service under this warranty, it is the responsibility of the purchaser to promptly notify the local Taco stocking distributor or Taco in writing and promptly deliver the subject product or part, delivered prepaid, to the stocking distributor. For assistance on warranty returns, the purchaser may either contact the local Taco stocking distributor or Taco. If the subject product or part contains no defect as covered in this warranty, the purchaser will be billed for parts and labor charges in effect at time of factory examination and repair.

Any Taco product or part not installed or operated in conformity with Taco instructions or which has been subject to misuse, misapplication, the addition of petroleum-based fluids or certain chemical additives to the systems, or other

abuse, will not be covered by this warranty.

If in doubt as to whether a particular substance is suitable for use with a Taco product or part, or for any application restrictions, consult the applicable Taco instruction sheets or contact Taco at (401-942-8000).

Taco reserves the right to provide replacement products and parts which are substantially similar in design and functionally equivalent to the defective product or part. Taco reserves the right to make changes in details of design, construction, or arrangement of materials of its products without notification.

TACO OFFERS THIS WARRANTY IN LIEU OF ALL OTHER EXPRESS WARRANTIES. ANY WARRANTY IMPLIED BY LAW INCLUDING WARRANTIES OF MERCHANTABILITY OR FITNESS IS IN EFFECT ONLY FOR THE DURATION OF THE EXPRESS WARRANTY SET FORTH

IN THE FIRST PARAGRAPH ABOVE.

THE ABOVE WARRANTIES ARE IN LIEU OF ALL OTHER WARRANTIES, EXPRESS OR STATUTORY, OR ANY OTHER WARRANTY OBLIGATION ON THE PART OF TACO.

TACO WILL NOT BE LIABLE FOR ANY SPECIAL, INCIDENTAL, INDIRECT OR CONSEQUENTIAL DAMAGES RESULTING FROM THE USE OF ITS PRODUCTS OR ANY INCIDENTAL COSTS OF REMOVING OR REPLACING DEFECTIVE PRODUCTS.

This warranty gives the purchaser specific rights, and the purchaser may have other rights which vary from state to state. Some states do not allow limitations on how long an implied warranty lasts or on the exclusion of incidental or consequential damages, these limitations or exclusions may not apply to you.



A Taco Family Company

Taco, Inc., 1160 Cranston Street, Cranston, RI 02920 | Tel: (401) 942-8000 | FAX: (401) 942-2360

Taco (Canada), Ltd., 8450 Lawson Road, Suite #3, Milton, Ontario L9T 0J8 | Tel: (905) 564-9422 | FAX: (905) 564-9436

Visit our web site: www.TacoComfort.com | Printed in USA | ©2021 Taco, Inc.

