

SUBMITTAL DATA SHEET

Iron Body Gas Plug Valves less Lockwing -559 Series

FNPT x FNPT



SIZE	A	B	C	D	E	F	G
1/2	3.14	3.16	1.66	.59	1.62	1/2	1/2
3/4	3.14	3.16	1.66	.59	1.62	3/4	3/4
1	3.36	3.53	1.86	.59	1.94	1	1
1 1/4	3.88	4.38	2.38	.65	2.31	1 1/4	1 1/4
1 1/2	4.66	4.99	2.66	.62	2.62	1 1/2	1 1/2
2	5.60	5.57	2.96	.59	3.00	2	2

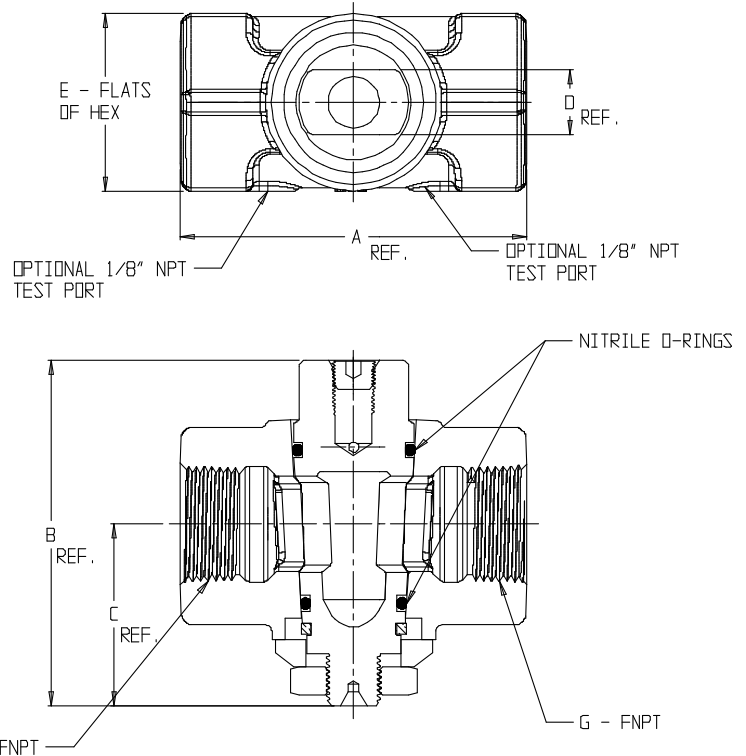

SUBMITTAL INFORMATION

- Manufactured in compliance with ANSI/ASME B16.33 (latest revision)
- Brass castings conform to ASTM B584, UNS C83600 or C84400 (latest revision)
- Iron castings conform to ASTM A126 Class B Iron, with optional zinc coating per ASTM B633 with clear chromate coating and silicate sealer (latest revisions)
- Rated for 175 PSIG natural, manufactured, or LP gas pressure
- Valve can be re-lubricated while in service and under pressure
- Plug rotates 360°
- Tamper-resistant design prevents disassembly with normal household tools
- Port opening sized to accommodate the best known stop changers



A.Y. McDonald Mfg. Co.
P.O. Box 508
Dubuque, IA 52004-508

Toll Free: 1-800-292-2737
Fax: 1-800-832-9296
Hours: 7:00 a.m. – 5:00 p.m., CST

sales@aymcdonald.com
www.aymcdonald.com

A.Y. McDonald considers the information on this assembly drawing correct when published. Item and option availability, including specifications, are subject to change without notice.

Submitted by: